

Today's Understanding of the Function and Benefits of Dummy Block Design

Paul Robbins¹, Bill Dixon², Ken Chien¹ and Chris Jowett³

¹ Castool Tooling Systems, Uxbridge, Canada

² QED Extrusion Developments, Escondido, USA

³ Rio Tinto, Kingston, Canada

ABSTRACT:

The paper reviews the development of the dummy block from the early days of the loose pad to today's high pressure, quick expansion fixed version. Residual aluminum skin thickness measurements taken on containers from production presses, supported by finite element analysis of deflections of both dummy block and container under typical temperature and pressure distributions, are presented. The impact of temperature and pressure is discussed in relation to the functioning of the container and block, both when performing as intended and when acting out of harmony.

The paper concludes with a comments section that establishes the design and best operating practices to maximize block life and minimize the deleterious effects of trapped air and back end defect and coring.

INTRODUCTION:

As extruders continue to optimize productivity by maximizing both equipment uptime and product recovery, the role of dummy block performance is key in achieving these fundamental objectives toward extrusion excellence. Extended dead cycles can be avoided, when associated with alloy build up on the outer bearing surface of an ill-functioning dummy block, as can extrusion scrap due to blister, with improved dummy block design.

Today's dummy blocks are complex in design with multiple interactive components, and the performance demands are high in comparison to earlier dummy blocks where the sole function was little more than to transmit the extrusion force from the stem onto the rear face of the billet in order to facilitate extrusion, and be a close fit in the container to avoid backward extrusion. In the early days of extrusion, loose dummy blocks were of simple design and as the name implies were loose cylindrical blocks of tool-steel. These loose blocks were often used cold - 2 or more in circuit, and often quenched to cool before re-entry into the press. The block usually remained attached to the butt at the end of extrusion, and requiring separation from the butt after butt shear. The blocks were then returned via a chute and lifter to be reused in the next extrusion. In truth, the simple one-piece solid design had limitations; it provided no capability to expand and contract in a controlled manner, separation from the butt and the rotation of multiple blocks and the associated handling could be fraught with problems, and significantly extended the press dead cycle. The fit between the block and the heated container liner was questionably controlled and without doubt liner life was influenced by dummy block scoring and premature wear. Despite the disadvantages that have caused the almost complete replacement of loose pads with fixed dummy blocks, it still remains a fact that coring / back end condition can be significantly reduced by the use of a cold / loose block^[1]. The development of a cooled fixed block remains a "dream" which could revolutionize the hot extrusion process. While loose dummy blocks remain in occasional use on some indirect extrusion presses today, for direct extrusion presses they have evolved in design to incorporate the many features of a modern day dummy block, designed to be fixed to the stem and perform consistently and reliably for many extrusion cycles. While the exact date of the introduction of fixed dummy blocks is uncertain, it is known that Alcan first installed a design on a press in Alcan Canada Products, Kingston, ON. in 1974^[2], and it is reported NLM introduced fixed dummy block technology onto their presses in Japan also in 1974. Initially, following NLM, fixed blocks were fixed to the press with a threaded rod through the hollow stem. This was the practice till at least 1988 when the bayonet fitting was introduced. This remains the industry standard.

Both Bessey and Castle presented designs of a fixed dummy block at ET'88^[3, 4]. Robbins et al reviewed the design, operation and maintenance of dummy blocks at ET 2000^[5] and compared the performance of fixed versus loose designs at ET 2004^[6]. This also included some FEM studies predicting block expansion under applied load. The requirements for a modern dummy block are multiple and too often underestimated in terms of importance toward trouble free, defect free and optimized extrusion. A successful dummy block must satisfactorily perform the following:

- Expand under load to a known diameter & contract on removal of load to close to the original nominal diameter.
- Generate a thin controlled skin on the container liner wall, allowing the dummy block to clear the skin on stem retraction without build up.
- Expand sufficiently to generate a thin gap under the dynamic conditions of extrusion, avoiding backward extrusion and blow by under extrusion forces.
- Allow entrapped air to escape from the rear of the billet during the burp cycle.
- Be easy to maintain, with replaceable wear parts.
- Be quick and simple to replace during production.
- Have a long service life.

Recently^[7], Robbins and Chien emphasized the importance of the interaction between dummy block and container expansion under extrusion conditions of temperature and applied pressure. The content of this paper expands on that work with particular emphasis on improved dummy block understanding and design.

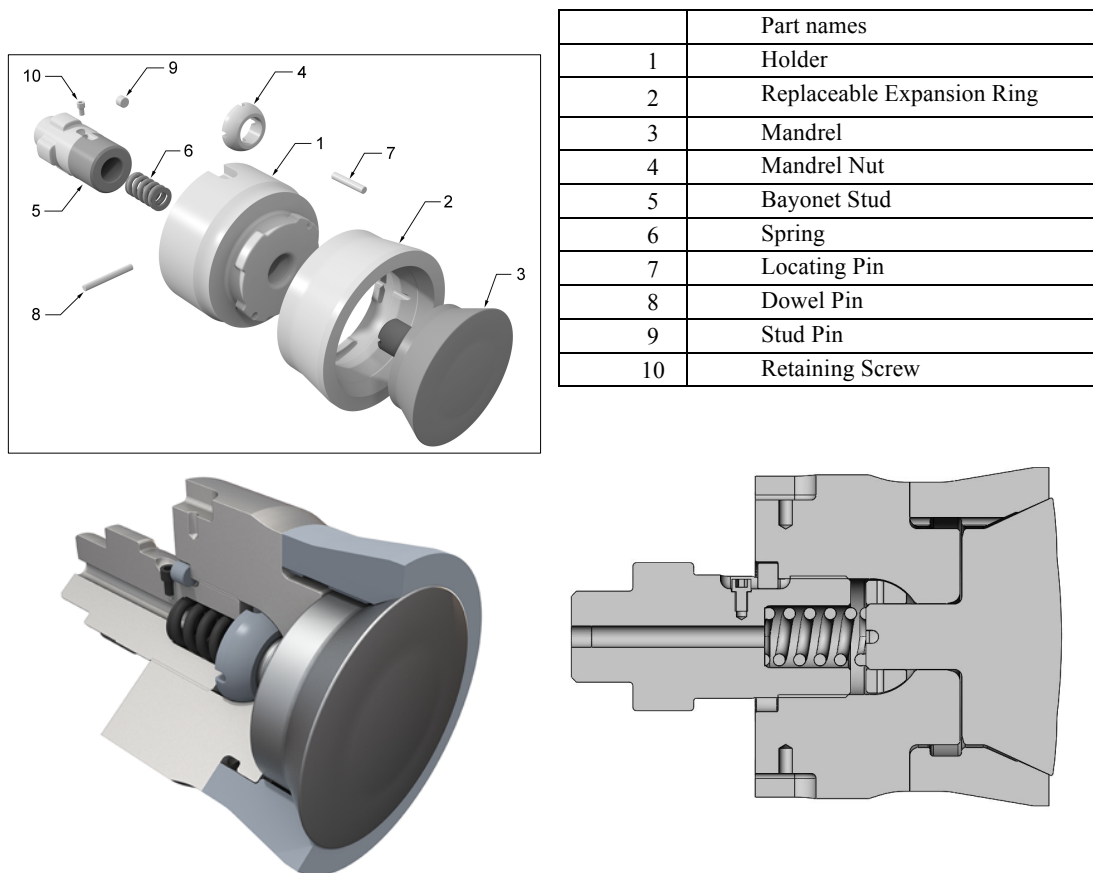

Figure 1: Component parts in a modern dummy block design (Castool Type RRB).

Figure 1 displays the component parts in a typical fixed dummy block commonly in use on many presses today. Most fixed dummy block designs incorporate an expansion ring, which expands radially by nature of a lateral extrusion force applied to the face of the conical mandrel. Each component is manufactured from hot working tool steel (typically H-13 or variants of H-13) and heat treated to a desired hardness to enable the combined parts to accomplish their specific roles to expand and retract on removal of the extrusion force, as intended in a well designed dummy block.

The dummy block illustrated in Figure 1, along with similar designs have performed well in service until recent years and the advent of higher specific presses, notably compact front loading presses offering increased billet length capability. These modern presses by nature apply higher extrusion forces and pressures on the face of a dummy block, i.e. up to the press maximum specific pressure which may reach 825 MPa (120,000 psi). This risks components exceeding their high temperature yield stress, thereby challenging designs to expand and retract in a controlled and consistent manner. This is addressed in the paper, as is the behavior of a dummy block under applied pressure and extrusion cycles following FEM studies conducted in cooperation with Altair using both HyperXtrude® and OptiStruct® software. The FEM studies also cover the relationship between container expansion and the interaction with dummy block expansion which is further reported in an additional paper at ET2016^[8].

In light of the aforementioned high operating pressures, the design of a dummy block can be fraught with challenges, namely the steel exceeding its operating yield stress at elevated temperature and the dummy block expansion being constrained by the container. Additionally, the expansion can be constrained by the aluminum alloy skin (or skull) deposited on the container liner inner surface, generated by the dynamic gap between the dummy block and the liner. These challenges are addressed, and solutions presented in terms of an improved dummy block design to operate under the higher applied pressures of today. Work continues on better understanding the dynamic behavior of the gap between dummy block and container, and generation of the aluminum skull on the liner.

THE ROLE OF EXTRUSION PRESS SPECIFIC PRESSURE:

Recent developments with extrusion presses include short stroke front loading direct extrusion presses. This press construction tends to be the design of choice with new plant investments, and understandably so due to advanced FEM designs, improved and high quality main component materials, improved alignment, advanced hydraulics and controls, dead cycles of 15 secs or less on typical 8" presses, and container lengths, up to 1.3m. The potential for improved extrusion productivity using these presses is therefore significant - longer billets equal increased contact efficiency percentage (i.e. the accumulated "on pressure" push cycle expressed as a percentage of the total cycle time, including the dead cycles). Furthermore, the shorter dead cycles and improvements in component reliability, electronics, controls and tooling, result in reduced downtime and increased utilization, and improved contact time expressed as a percentage of total manned time. But these presses with longer billet length capability, require higher specific pressures - or more press tonnage for a given container diameter.

Figure 2 illustrates the effect of billet length on specific pressure, and why today's longer container presses must operate with higher tonnage for a given container diameter, and at higher specific pressure to maintain the necessary die face pressure and enable extrusion without jeopardizing productivity and ram speed.

While it can be argued that lower specific pressure can be utilized with a longer billet by employing a higher billet temperature, ram speed and productivity will be compromised. Taper heated billets will be necessary, with tapers that may exceed the capabilities of direct gas fired preheat ovens, commonly used on the majority of presses, thereby requiring induction heater generated taper, or billet taper quenching usually after preliminary gas fired preheat.

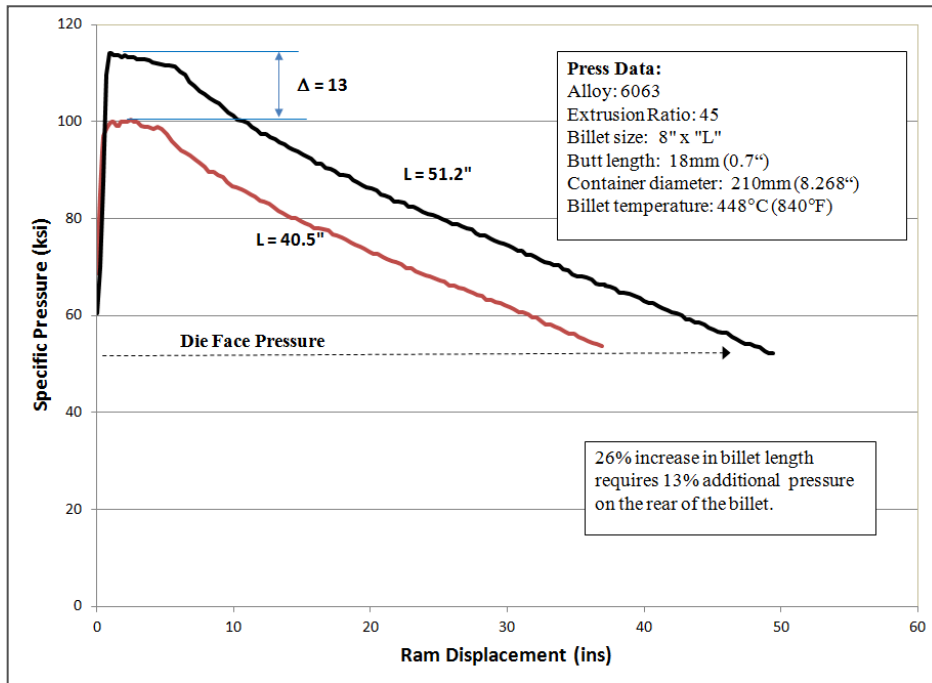

Figure 2: Effect of billet length increase on specific pressure.

A typical press of not many years ago, would extrude commodity products in 6063 or 6060 alloy, operating at a specific pressure of around 480 - 600 MPa (70,000 - 85,000 psi), with maximum billet lengths no more than approximately 4 times the billet diameter - for example, a direct rear loading 2000MT/210mm press with a specific pressure of 570 MPa (82,000 psi) extruded up to 32" (810mm) long billets. Considering a modern front loading press of 25MN force with a 210mm container (8" billet), the specific pressure is 720 MPa (105,000 psi) and a maximum billet length of 47" (1.2m), or almost 6 times the billet diameter - 28% higher specific pressure and 47% longer billet length capability.

To maintain die face pressure to enable extrusion under the selected extrusion conditions when using a 26% longer billet, a 13% increase in specific pressure is required to overcome additional billet container friction associated with longer billet lengths. Such presses operating at higher specific pressure to overcome billet container friction associated with longer billet lengths, require careful consideration regarding optimum operating conditions in addition to imposing additional demands on dummy block design.

Therefore higher specific pressures may now be encountered, which may subject the face of a dummy block to stresses close to and exceeding the yield stress of H-13 steel at typical dummy block operating temperatures of between 365°C and 450°C. Figure 3 illustrates H-13 mechanical properties at elevated temperature. Table 1 and Figure 4 show the physical property data and idealized stress-strain curves used in the study for H-13 steel at temperature.

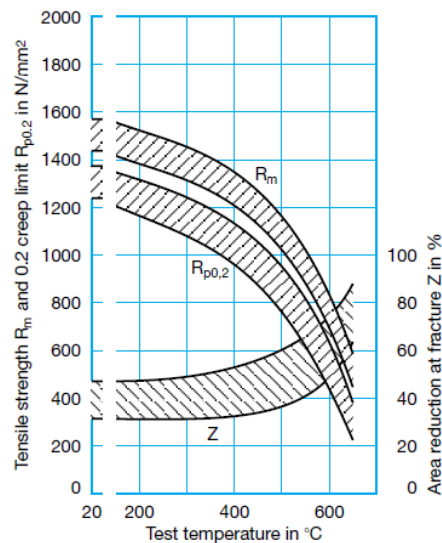

Figure 3: Elevated temperature properties of H-13 (1,2344) hot working tool steel courtesy of Thyssen^[9].

The stress levels under high applied pressures for both current and improved high pressure designs of dummy blocks are shown later.

Table 1: Physical Property Data used for H-13 steel at temperature.

Temp. (°C)	Modulus E (GPa)	Yield Stress Fty (MPa)	UTS Ft _u (MPa)	Stress @ break F _b (MPa)	Strain @ yield e _y	Strain @ ultimate e _u	Strain @ break e _b
250	187	1346	1554	1555	0.0072	0.0336	0.06
350	187	1288	1498	1499	0.00689	0.0334	0.06
450	187	1150	1400	1401	0.00615	0.0331	0.06

Poisson's Ratio (ν)	0.29
Density Mg/mm ³	7.80E-09
CTE (α)	1.30E-05
Ambient Temp (T _{ref})	293K
Elong % @ break	0.06

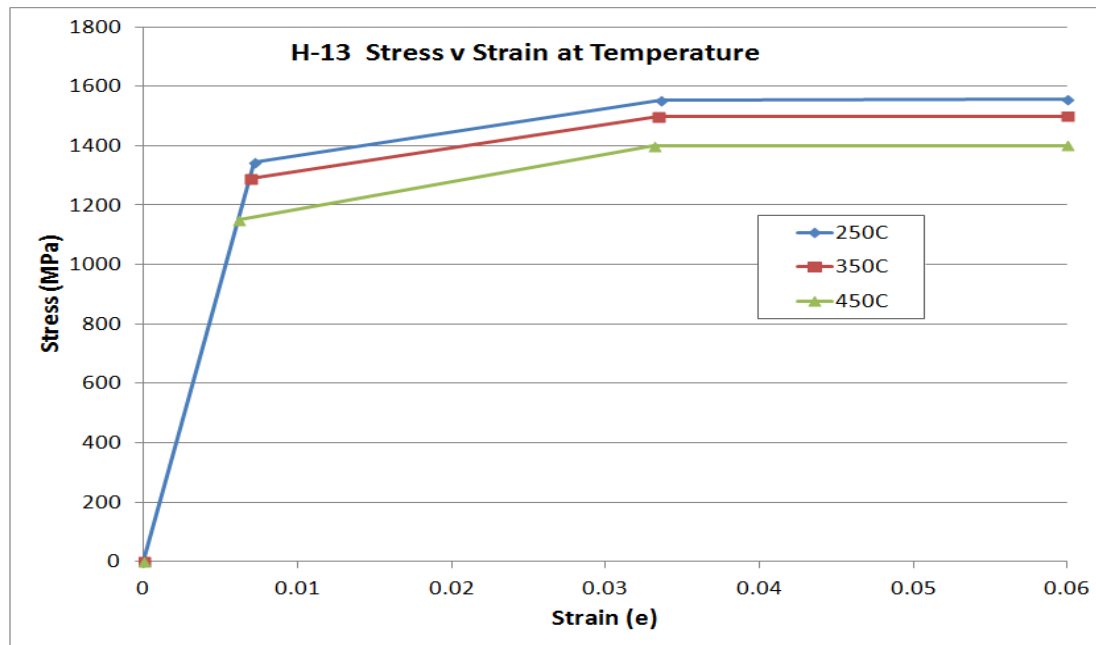

Figure 4: Idealized stress-strain curves for H-13 steel at temperature.

PERFORMANCE OF A STANDARD DUMMY BLOCK DESIGN:

First, consider the standard design of a Castool RRB (replaceable ring) dummy block shown in Figure 1. The following applies to a nominally 8" diameter design. As initial extrusion pressure is applied, the ring first expands elastically under a relatively low applied facial pressure of approximately 34 MPa (5000 psi) closing the pre-established gap between the mandrel and holder. This equates to no more than 140 tonnes applied force. The gap and the mating angle between the mandrel and the ring results in an initial "settling down" expansion of 0.65mm in diameter.

Thereafter, the higher pressures required to upset the billet and then extrude, are applied. The dummy block must perform under these conditions, which may reach the maximum possible for the press, i.e. up to 825 MPa (120,000 psi). Figure 5 shows dummy block expansion behavior under such high pressure and in an unconstrained environment, i.e. without resistance offered by the liner surface. The graph shows two

lines, one giving the mechanical expansion under the applied pressure, and the other showing "total" expansion including additional thermal expansion of 1.17mm at an operating temperature of 450°C.

There are three distinct regions of behavior: First, the initial elastic deformation stage associated with settling down, i.e. around 5000 psi. Second, an extended elastic deformation stage up to around 80,000 psi, where the rate and amount of expansion are not only determined by the angle of the ring and the gap between mandrel and holder, but also by a Poisson's ratio effect where axial compression of block components results in additional radial expansion. Finally, the third stage at pressures beyond 80,000 psi, indicates a deviation from linear elastic behavior with some components now exhibiting plastic deformation. To design an optimal dummy block to operate under such high pressure challenging conditions, requires a full understanding of the stress distribution, not dismissing that some limited component yielding may be tolerable, yet the dummy block as a unit remains fully functional.

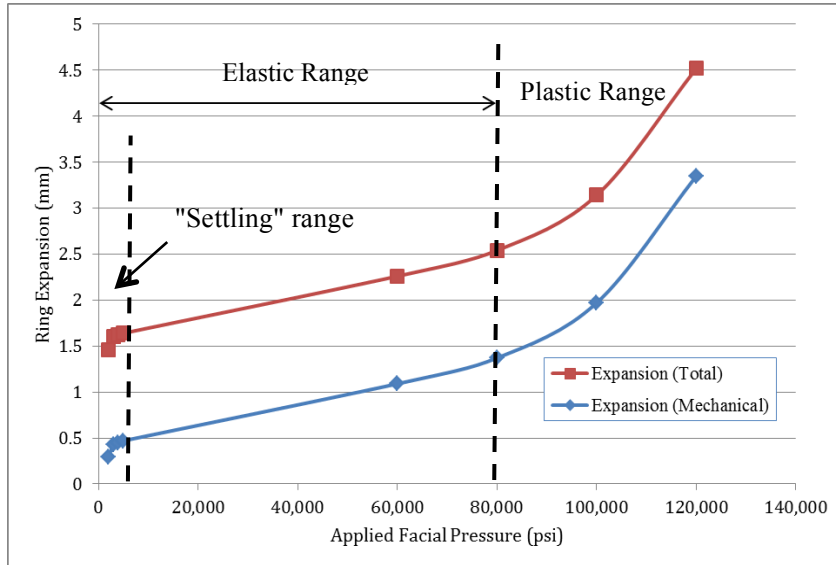

Figure 5: Unconstrained Diameter Expansion of an RRB Dummy Block under applied facial pressure – showing 3 stages of behavior.

LIMITATION OF A STANDARD DUMMY BLOCK DESIGN:

Most commercially available dummy blocks operate satisfactorily under applied pressures (or press specific pressures) of 700 MPa (100,000 psi) or less. Yet only a few designs provide good repetitive performance and long service life. While limited yielding occurs in some components - notably the expansion rings - the extent is generally tolerable at these relatively lower applied pressures. Known in the industry as "set", this limited permanent yield is often machined back by extruders after a short initial in-service life of typically around one week. Thereafter, the dummy block can enjoy more satisfactory, consistent and extended service.

However, under higher applied pressures of 825 MPa (120,000 psi) permanent yielding of a standard low pressure dummy block can become more severe, and overall performance and function of the dummy block can suffer. Permanent deformation of the ring can become excessive at these high pressures (Fig 6) resulting in the dummy block failing to satisfactorily retract when extrusion pressure is removed. Now the dummy block may fail to clear the container and skin during withdrawal and alloy may be picked up from the container skin after relaxation of the container liner. The resulting alloy from the container skin collects on the rear of the bearing land, influencing how a dummy performs during the burp cycle. This risks more blisters on extrusion surfaces, creates press downtime due to the need to frequently clean or

prematurely change the dummy block, plus product scrap at the press saw, or downstream. Von Mises (maximum) stress contours for the same dummy block under equal pressure and temperature conditions are shown in Fig 7.

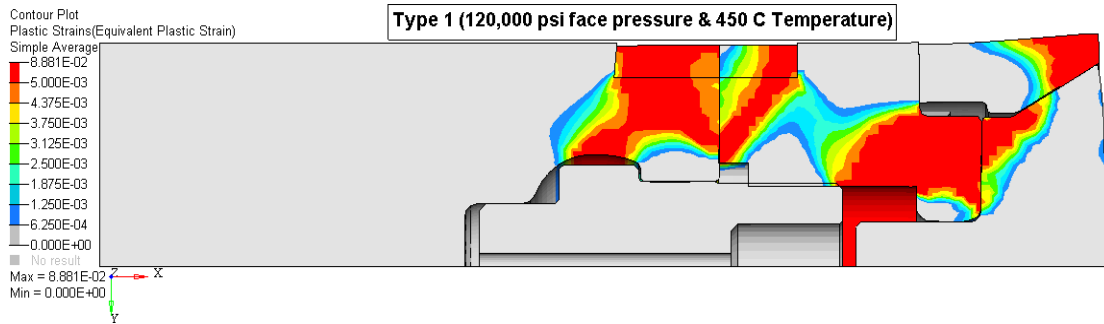

Figure 6: Plastic Strain contours for a standard (low pressure) RRB dummy block, when subjected to a modern press high specific pressure of 825 MPa (120,000 psi), showing yielding of H-13 tool steel components.

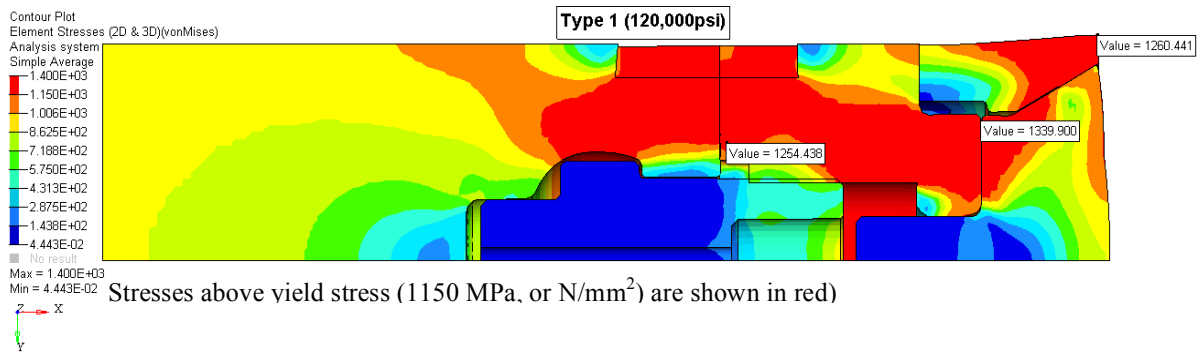

Figure 7: Von Mises stress contours for a standard low pressure RRB dummy block, at a specific pressure of 825 MPa (120,000 psi), showing stress regions above the yield stress at operating temperature of 450°C.

In addition, and in certain circumstances, high extrusion ratio products in softer alloys (1xxx and 3xxx) may result in backward extrusion over the dummy block if the necessary applied pressure on the rear of the billet is high enough - which is likely be the case with longer billets. Clearly conventional low pressure dummy blocks, able to perform satisfactorily in most lower pressure situations, cannot perform under the demands of higher specific pressure presses. A solution is therefore required to enable a dummy block to operate reliably under the higher specific pressures in today's modern presses, and cater for a wide range of alloys and products likely to be extruded.

DESIGN FOR HIGH PRESSURE APPLICATIONS:

The task is daunting to design a multi-component dummy block to operate under the high specific pressures of today. The dummy block has not only to resist excessive yielding under high temperature and high pressures, but has to function in terms of controlled expansion and contraction, and to work together with container liner expansion and sufficiently clear the aluminum alloy skin at the end of the extrude cycle, then draw back through the container without dragging alloy from the liner. In addition, it has to avoid too much clearance and blow by with specific alloy/product combinations. After a number of iterations, a modified design illustrated in Figure 8 was finalized to satisfactorily cater for pressures up to 825 MPa (120,000 psi). Component contact areas were increased to reduce applied stresses, along with other design features to improve force and pressure distribution throughout the dummy block. The effect of the redesign in reducing plastic strain under load is illustrated in Figure 9 (compare with Figure 6), and the effect in reducing the component stress levels is shown in Figure 10 (compare with Figure 7).

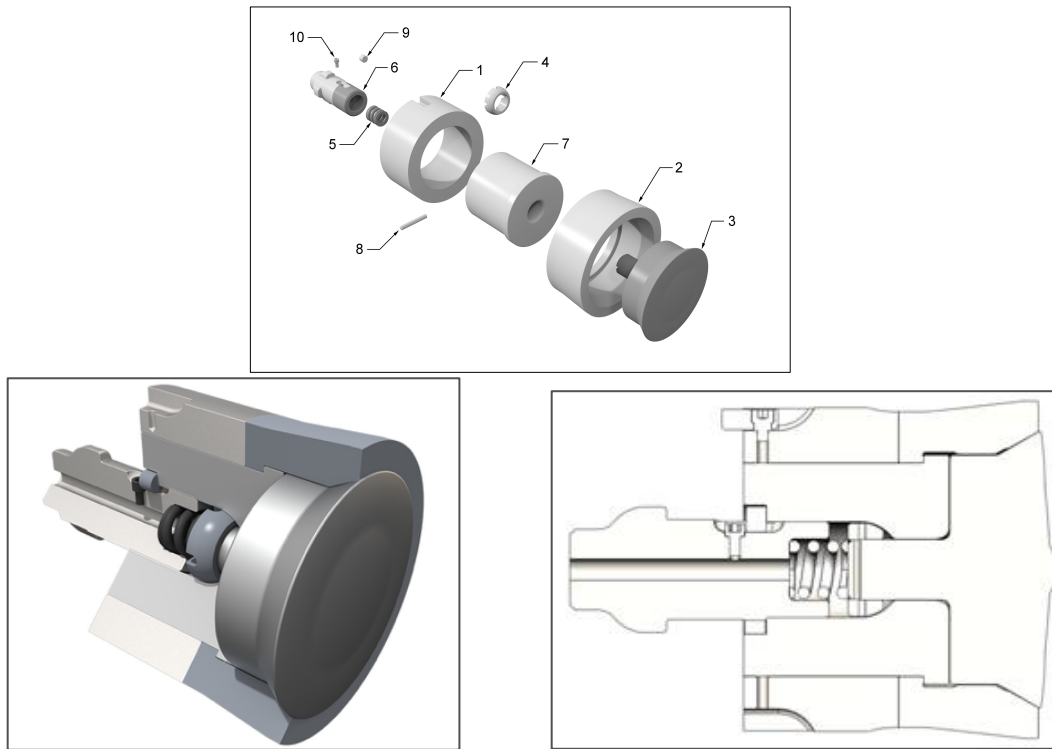

Figure 8: Improved Dummy block Design to accommodate high applied pressures at elevated temperature.

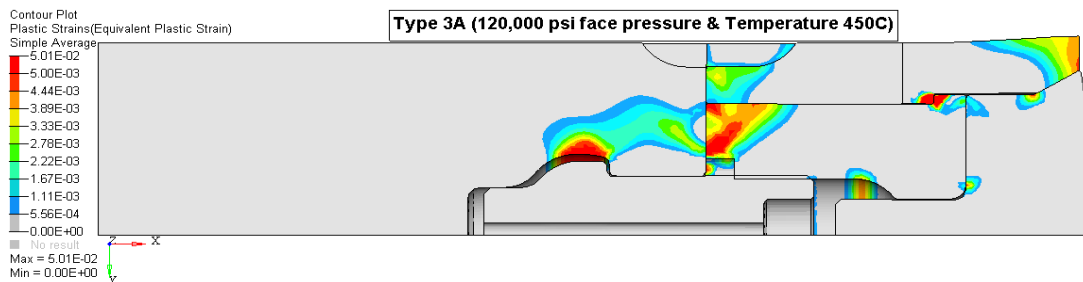

Figure 9: Improved High-Pressure Dummy Block Design - Plastic Strain Distribution at a specific pressure of 825 MPa (120,000 psi), showing reduced yielding of H-13 tool steel components.

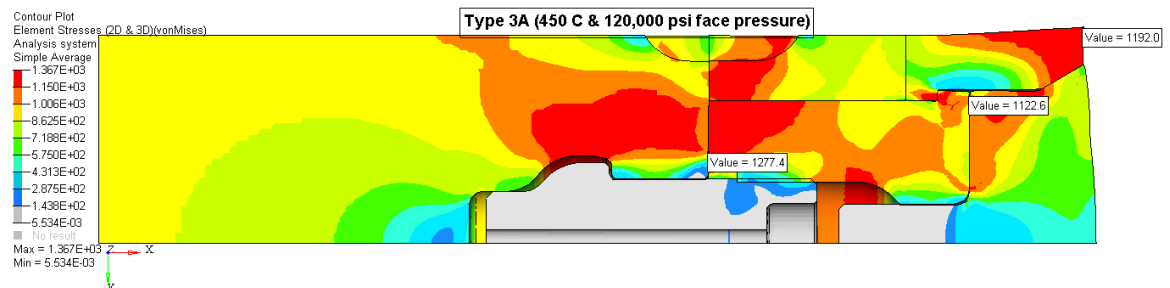

Figure 10: Improved High-Pressure Dummy Block Design - Von Mises stress contours at a specific pressure of 825 MPa (120,000 psi).

The new high pressure dummy block design satisfactorily reduces component stress levels to more tolerable levels, and is capable of working better under the extreme conditions of high applied stress.

RELATIONSHIP BETWEEN DUMMY BLOCK EXPANSION AND CONTAINER EXPANSION:

Ideally both the dummy block and container need to be designed to perform and expand synchronously when subjected to extrusion pressure, with the key objective to produce a minimum and consistent container skin. The importance of skin generation is now well understood, with a number of workers^[10-14] reporting the joint role of container skin along with billet surface segregation and how they together influence, and if too deep, encourage forward Type 1 flow of contaminated and enriched material onto the die and extrusion surface. The container skin is simply retained billet skin adhered to the liner due to sticking friction which is believed to behave in a dynamic manner, at times flowing backward (Type 2 flow). This collects as residue in the discarded billet butt, but has a risk of also flowing forward any time along with billet surface onto the extrusion surface and contributing to extrusion surface defects such as pickup and die lines - all happening while further billet skin is being deposited on the container liner. Thus a dynamic process of depositing and shedding is operating continuously. Skin generation and skin thickness are therefore important in influencing not only extrusion surface quality, but also productivity as measured by extrusion speed, as enriched composition skin and billet surface layers inflowing onto extrusion surfaces, can also lead to premature onset of speed related defects.

Lack of synchronized expansion of the dummy block and container will result in an inconsistent gap between the two and a variable skin thickness on the container liner. Unfortunately, in practice one type of dummy block design may be used with different container designs and vice versa. Many extruders therefore suffer inconsistent skin generation - worse, blow by with associated alloy build up, or damage to the container skin because of lack of clearance, that cannot be resolved even with diligent attention to matters such as alignment. This can be simply because the dummy block of choice does not expand in harmony with the container, or the initial design clearance between dummy block and container is incorrect. The dummy block and container relationship is addressed in more detail in the additional paper^[8], however some of the findings are presented below as they are considered relevant to the context of this paper, and the development of an optimized dummy block.

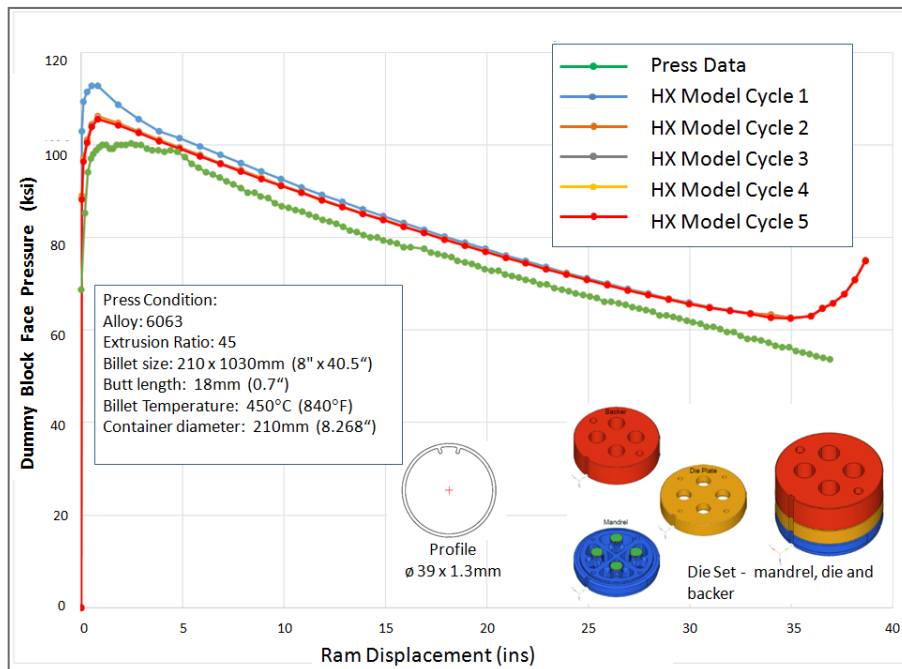

Figure 11: Dummy Block Face Pressure v Ram Displacement. Extrusion Data and Model Prediction.

Actual extrusion pressure curves were recorded for a selected 4-hole hollow extrusion on a 25MN, 8" front loading direct extrusion press. The process was then FEM modeled using a 1100mm long QR

container and a new improved high pressure (HPR) block. The simulated pressure curves are shown for 5 successive extrusion cycles superimposed on the actual press data in Figure 11, i.e. extrusion specific pressure (or pressure applied to the face of the dummy block) versus ram displacement. The predicted model data, is within 5% higher than the real press data, and the model was therefore considered acceptable and accurate in predicting pressures on both the dummy block and container during extrusion cycle simulations. After 5 simulated extrusion cycles, the process was considered stable allowing both container and dummy block expansion to be predicted with confidence. The findings are shown in Figure 12, along with an estimated skin thickness based on the difference between the dynamic container and dummy block expansions, i.e. combined thermal and mechanical expansion under varying extrusion pressure and as the dummy block passes through the container from start of extrusion to the final position of the butt length. The extrusion conditions and container zone temperature settings are displayed in the text box in Figure 11.

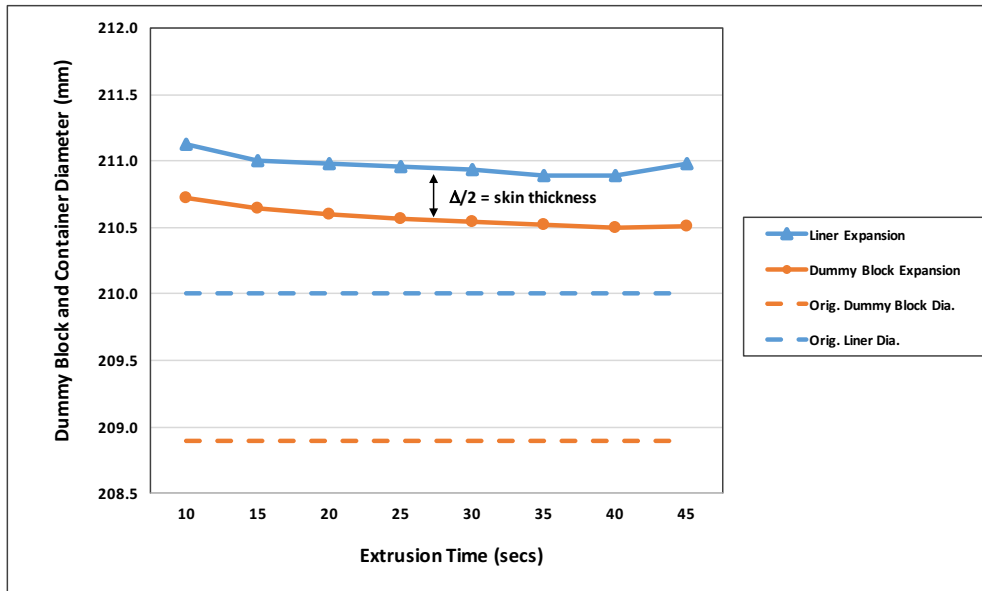

Figure 12: Model predictions of container expansion, dummy block expansion, and container skin thickness under extrusion conditions.

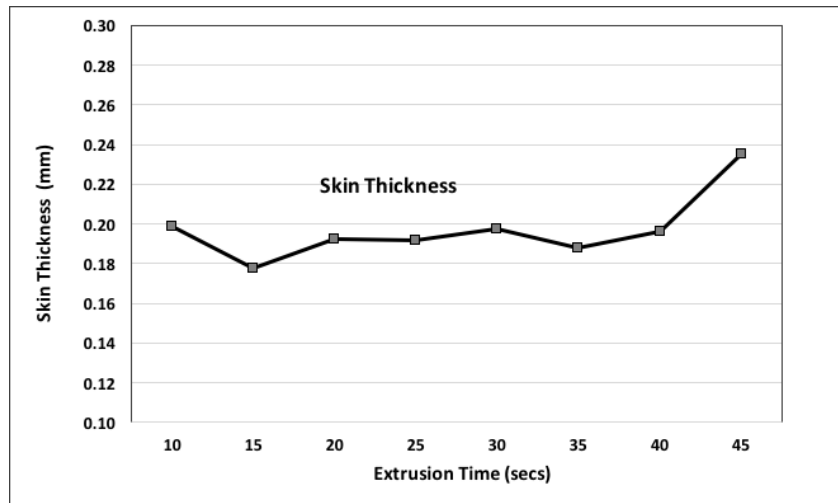

Figure 13: Predicted container liner aluminum skin thickness as computed from the liner and dummy block expansion data (Figure 12).

Figure 12 illustrates the gradual reduction in expansion of both container and dummy block as the applied pressure on the rear of the billet and dummy block face reduces when the stem advances during the extrusion cycle. Interestingly predicted skin thickness as illustrated in Figure 13 varies little and remains essentially constant around 0.18mm, indicating harmonious behavior of both the container and dummy block. The dummy block diameter at ambient temperature is 208.9mm. It is worth noting that dummy block expansion under extrusion conditions is constrained by both the surrounding container and the interfacial skin. Dummy block expansion is therefore less than illustrated earlier (Figure 5) when expansion was analyzed under unconstrained conditions. The dummy block internal friction coefficient in this analysis was 0.75

THE EFFECT OF FRICTION BETWEEN THE DUMMY BLOCK COMPONENTS:

Unconstrained expansion under pressure was covered earlier for the lower pressure RRB type dummy block (Figure 5), where the data assume no friction between internal components that have the ability to slide against each other. A common practice, and one recommended by most dummy block manufacturers, is that dummy blocks are dismantled and inspected on a regular basis (i.e. weekly). In some instances, extruders coat the inner moving components, such as the mandrel and inner surface of the ring with a boron nitride solution to reduce friction. The effective friction coefficient is therefore unknown and variable from plant to plant, and possibly from dummy block to dummy block. Due to a lack of common inspection and maintenance practices across extrusion plants, plus some tolerable degree of yielding in component parts, the extent a dummy block may expand will vary.

While it is recognized there are many unknown factors contributing, the effect of friction was studied by introducing a friction coefficients (μ) ranging from 0 to 1 into the analyses. The findings are shown in Figure 14 and Table 2 showing for comparison the effect of friction on total ring expansion for both the low pressure RRB block, and the high pressure HPR block. An estimate of a realistic practical friction coefficient range of $\mu = 0.7-0.85$ is shown.

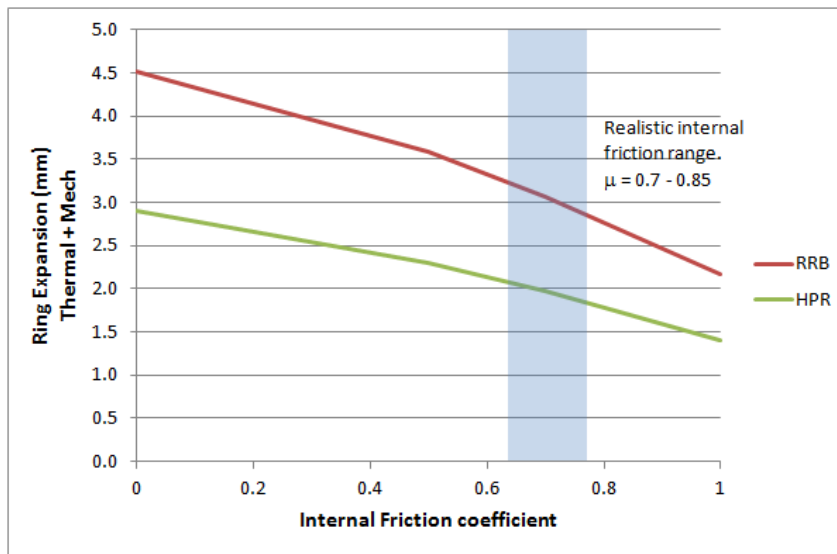

Figure 14: Effect of Internal Friction on Dummy block Ring Diameter Expansion (8" block under 825 MPa, or 120,000 psi applied pressure and 450°C). Data shown are for both RRB and HPR dummy blocks.

Table 2: Data showing both thermal and mechanical expansion of the dummy block, that together amount to the total diameter illustrated in Figure 13 above.

Friction coefficient (μ)	Ring Diameter Expansion (mm) at 120,000 psi applied face pressure					
	RRB			HPR		
	Thermal	Mechanical	Total	Thermal	Mechanical	Total
0	1.17	3.35	4.52	1.17	1.73	2.90
0.5	1.17	2.41	3.58	1.17	1.13	2.30
0.7	1.17	1.90	3.07	1.17	0.81	1.98
1	1.17	1.00	2.17	1.17	0.23	1.40

The data in Figure 13 and Table 2 show that friction between component parts in a dummy block has a major influence on the expansion. Recognizing that 1.17mm of the total expansion is thermal, which itself is not influenced by any friction, the mechanical expansion alone can be seen to differ significantly from 1.73mm to 0.23mm when comparing frictionless to full friction scenarios. In the expected friction coefficient range of 0.7-0.85, a HPR dummy block is likely to expand under high pressure loading up to 2.0mm in total, approximately 1.2mm thermal, and 0.8mm mechanical.

The data emphasize the significance of friction in a dummy block and the important role of dummy block internal surfaces and maintaining as near possible constant friction conditions to ensure consistent and reliable service.

EFFECT OF ALLOY AND EXTRUSION CONDITIONS ON DUMMY BLOCK DESIGN Including trials with the new High Pressure Dummy Block.:

This work has demonstrated the need to develop a high pressure dummy block to perform satisfactorily under higher applied pressures common today. It has also highlighted the challenges in dummy block design to accommodate the variables associated with different container designs and thermal behavior of containers. The effect of alloy and extrusion conditions must also be considered.

It is known that a dummy block must expand and retract under controlled conditions to generate a stable yet thin container skin without the risk of backward extrusion (or blow-by) over the dummy block under the higher pressure conditions at the start of the pressure cycle. Whether or not backward extrusion occurs depends upon the active clearance between the dummy block and container under operating conditions of temperature and applied pressure - the active clearance being the real clearance during extrusion, or the effective skin generation thickness on the container liner wall. However, the active clearance is also dependent on the initial cold clearance incorporated into the design, i.e. the difference in diameter of the cold dummy block and the cold container liner under a no-pressure situation. This initial cold clearance may need to be customized for some operations, and be different for a plant extruding 6xxx traditional alloys under standard conditions and at typical extrusion ratios (in what is considered the preferred range of 40-60) compared to a plant producing 1xxx or 3xxx alloys for micro-port heat exchanger or automotive a/c applications, where typical practices involve coiling of extrusions from full length billets at high extrusion ratios, at times in excess of 400. Another factor with the micro-port extrusions is that extrude cycle times can be lengthy in comparison to traditional 6xxx alloy cycles – i.e. 5-6 minutes compared with around 1 minute. The conditions for blow-by over the dummy block, and the tendency for the alloy to do so, are therefore quite different in these two situations.

For an alloy to extrude forward through the die aperture the applied pressure on the die face must exceed the flow stress of the alloy multiplied by the natural log of the extrusion ratio. This is the fundamental extrusion equation applicable at the die face, but ignoring friction through the die. At the die face, friction between the billet and container need not be considered. Flow stress for any alloy varies with temperature and strain rate, but the sensitivity of flow stress to temperature and to strain rate can differ with alloy. Fig 2 illustrated how applied pressure to the billet and dummy block face can be around 2 times the die face pressure to extrude, so the applied pressure to encourage back extrusion over a dummy block can

be twice that to extrude through the die. Mean strain rate, which can be estimated, or modeled at the point of die entry, and at the rear of the billet (or dummy block face), was not part of this current work, but it is clear the strain rate is considerably lower close to the dummy block, compared to where alloy is in the high deformation (high strain rate) zone entering the die. Furthermore, temperature is significantly higher in the billet when entering the die.

So this complex balance of parameters influencing the alloy flow stress and extrudability can lead to circumstances, depending on alloy, extrusion ratio, and chosen conditions of temperature and speed, where backward extrusion over the dummy block may occur, unless the active clearance between the dummy block and container liner is well engineered to avoid it happening.

Thus, customized dummy blocks designed with appropriate cold clearance to the container liner, thereby operating under pressure at the optimum active clearance, must be designed to suit the range of products produced on any press. In most cases a standard design will be appropriate for 6xxx series alloys operating in the typical extrusion ratio range of 40-60, and still be capable of performing satisfactorily outside this ER range within the total range typical on most commercial presses - i.e. 25 to 100. This current work has highlighted why special design variants, and initial clearances are likely to be necessary for high ratio extrusion and/or high operating pressure presses.

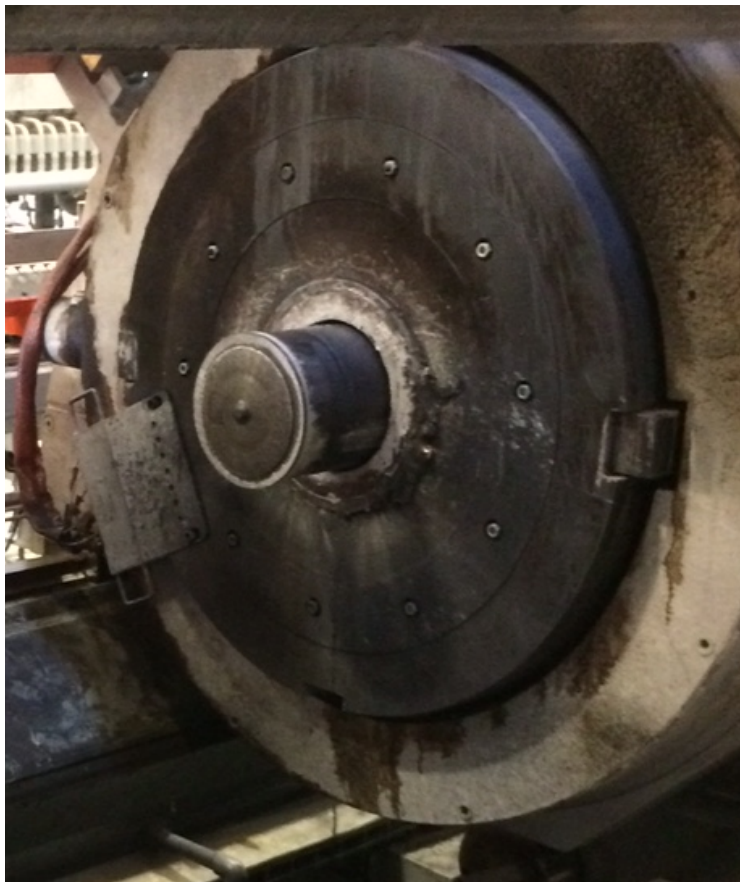

Figure 15: A new high pressure (HPR) dummy block satisfactorily working on a high specific pressure front loading press.

BENEFITS OF AN IMPROVED HIGH PRESSURE DUMMY BLOCK:

Considering the benefits of a high pressure dummy block design:

- **Able to resist high applied pressure.** The new high pressure (HPR) block has the ability to expand in a controlled manner under high pressure and in harmony with a container, thus producing a controlled and thin container skin. Component stress levels are reduced, and yielding minimized.
- **Custom designs.** The work demonstrated that under high applied pressure scenarios, some alloys other than 6xxx series, in combination with long billet lengths, high extrusion ratios and long contact time, may be susceptible to back extrusion, or blow-by over the dummy block. This can be overcome by customized design of a dummy block with adjustments to the initial cold clearance with the container, and internal component redesign to adjust dynamic expansion under pressure.
- **Reduced press downtime.** The amount of non-planned downtime accumulated in a shift due to operators attending to dummy block issues can be considerable. Dealing with events such as build up, applying additional lubrication to the dummy block - which too often is applied manually, and running clean out blocks in an attempt to overcome ongoing dummy block problems, are common happenings on front loading presses, that can be significantly reduced with an improved and more reliable dummy block design. In addition to non-planned downtime, is the sequenced clean out cycle for front loading presses. During clean-out the stem and dummy block are retracted further during a dead cycle, and at a predetermined cycle interval - typically every 5th cycle - to clean billet build up that accumulates on the container liner behind the dummy block. The clean out cycle extends a dead cycle typically by approximately 8 seconds, which is a considerable loss in production or considered as a 1.6 second extension to a typical technical dead cycle of 15 seconds. Improving the dummy block performance and increasing the frequency of running the clean out cycle therefore has a marked effect on productivity based on this benefit alone.
- **Improved in-service life.** The need to remove a dummy block under high pressure service every week or less to replace, will be less with the high pressure design. However, good practices such as rotating the dummy block 90° on a daily basis continue to be recommended to equalize wear, as does removing the dummy block weekly for inspection, cleaning and internal lubrication with a boron nitride dry powder compound. The paper highlights the role of friction between component parts within a dummy block, and illustrates how expansion can vary by a factor of 2 when comparing a frictionless block with one exhibiting sticking friction behavior. In reality, some friction will be in play, but for consistent performance, it is important to maintain as constant a state of lubrication within the block by following diligent inspection and maintenance procedures. In addition the importance of maintaining press alignment, especially the alignment between stem and press axis, and stem to container, is critical in improving both dummy block performance and in-service life.
- **Reduced blisters.** A well designed high pressure dummy block will expand and relax reliably and consistently during and after each burp cycle allowing release of any air entrapped around the rear of the billet during billet upset, and avoiding blister toward the back end of the extrusion length. Relaxation of the dummy block ring will also be sufficient to clear the relaxed container liner plus skin after each extrusion cycle, thus avoiding dragging of the container skin when the stem passes through, or the container passes over the dummy block during a dead cycle. This maintains a smooth container skin, minimizing the risk of air being entrapped along the container length during billet upset, and avoiding blister along the extrusion length.
- **Reduced billet surface inflow.** Billet surface inflow can create extrusion surface quality problems including increased pick up and die lines, and streaking after anodizing, by the process of direct inflow and/or via accumulation of billet surface in die pockets and hollow dies due to forward (Type 1) flow. Also billet surface inflow creates increased back end or coring problems due to reverse (Type 2) flow. It is now understood that "billet surface" flow is a combination of actual billet surface layers plus already deposited billet surface in the container. The early work on physical modelling of

billet skin inflow (ref 10) showed that the effective thickness of the “skin” is the sum of that left on the liner wall from the previous billet and the current billet inverse segregation layer. The paper by Reiso et al at ET 2012 (ref 14) confirmed the conclusions that the material on the liner bore is detrimental to the quality of the profiles. In particular maintaining a thin and smooth container skin contributes to less billet surface flow, and reduced surface quality rejections, with reduced back end quality issues resulting from coring.

CLOSING COMMENTS:

The initiator for this work was higher applied pressure on dummy blocks resulting from modern press designs offering longer billet length capability with longer containers built into compact front loading press designs, and the difficulties this imposes on both design and functionality of dummy blocks.

Applied pressures on dummy blocks regularly exceed 750 MPa (108,000 psi) in service, and at times up to 825 MPa (120,000 psi). While these pressures impose average stress levels below the yield stress of the most commonly used steel, namely H-13, peak stresses on individual components are shown to be higher and at times exceeding the yield strength at operating temperatures, thereby resulting in some plastic deformation, influencing performance of the dummy block.

For many years dummy blocks have been known to plastically deform after some time in service, and have been considered to some extent a disposable tooling item, at least requiring replacement after time of component parts, for example a replaceable expansion ring, after between 10,000 and 40,000 billets, or replacement of the expansion mandrel after 25,000 – 80,000 billets. However, under the higher pressures of today, dummy block designs considered in the recent past, can now no longer tolerate what equates to up to 13% higher pressure, and commonly having to be replaced in less than one week (or less than 3000 billets).

This paper outlines the challenges, and the study undertaken to better understand the behavior of a dummy block under both combined high pressure and elevated temperature, and furthermore constrained by the container during extrusion cycles. While the content of the paper discusses the levels of stresses encountered, and the amount of tolerable yielding that may occur even in a high pressure design, it should be recognized that the stresses developed have at all times been compared to typical yield stress behavior of H-13 at 450°C. Although it is appreciated and well known that dummy blocks in front loading presses operate under higher temperature conditions than a dummy block in a conventional rear loading. This is due to the longer residence time the dummy block spends inside the container of a front loading press, not only during the extrusion push cycle, but also during the dead cycle when loading the next billet. However, temperature gradients commonly used today in the billet, and in container heating, indicate that the dummy block is rarely, if ever, seeing temperatures as high as 450°C at the start of an extrusion push, i.e. when the applied pressure is the highest. For instance, taper heating of billet to (say) 10°C/dm (4.5°F/in) to realize more isothermal extrusion exit temperature conditions results in rear billet temperatures typically as low as 360°C (680°F). Plus smart QR containers with multi-zone temperature control usually operate with front to back temperature offsets large enough that the rear end of the container can be also as low as 320-360°C (608-680°F). Accordingly, the dummy block is encountering contact temperatures at the start of a push much lower than 450°C, and the steel is therefore better able to tolerate the high initial applied stresses with less risk of yielding. Toward the end of a push, when the dummy block may reach temperatures approaching 450°C, applied pressures are much lower. Therefore, this work has considered a worst case scenario of maximum applied pressure, and highest temperature likely to be achieved, and in reality true operating conditions in service will be more favorable.

By taking these worst case conditions, and applying them to both the existing low pressure design and a series of design improvements, the results indicate a high pressure design can yield considerably less than a conventional lower pressure design, and perform satisfactorily with high confidence. This in turn, produces reliable ring expansion and relaxation, giving a consistent container skin thickness, and less risk of blow-by or dragging container skin during stem retraction.

While a new design of high pressure dummy blocks better tolerate the higher pressures encountered during modern extrusion, for the design to operate optimally in all production situations, it must be capable of satisfying the demands of a wide range of alloys, and extrusion conditions. The paper addressed the complexities associated with this, and how it is necessary to customize a dummy block design to best suit the product extruded on a given press. While it is possible to design a standard high pressure dummy block for a wide range of 6xxx alloy products typically extruded on a single press, special design may be necessary for specialized extrusion of (say) high ratio, multihole and coiled extrusion in 1xxx or 3xxx alloys (multiport or tubular). The difference in design will be the initial clearance between container and dummy block - less clearance for high ratio soft alloy products - with adjustments to inner components such as the mandrel angle and gap, to better control dynamic expansion. Custom designs can therefore be provided.

ACKNOWLEDGEMENTS:

The authors would like to thank the many colleagues at Castool who helped contribute to this work, with special thanks to Danny Dunn for providing his practical experience and observations. Gratitude is also extended to Al Warner at Vitex Extrusions who helped provide the actual press data used as the basis of the extrusion simulation modeling.

Special thanks to Drew Burkhalter and David Durocher at Altair who performed and orchestrated the modeling work, and to their colleague Mahender Reddy who provided expert guidance.

And finally, appreciation to Rio Tinto for allowing Chris Jowett to join the team for this work, and to Chris for agreeing to co-author the paper.

REFERENCES:

1. Jowett, C., Parson, N., et al "Simulation of Flow of the Billet Surface into the Extruded Product". *Proceedings of the Seventh International Aluminum Extrusion Technology Seminar* (ET 2000), Vol I, pp. 27-42, Chicago, Illinois, May 2000
2. Private communication - R. Fielding Oct 2015
3. Bessey G., "The Fixed Dummy Block". *Proceedings of the Fourth International Aluminum Extrusion Technology Seminar* (ET 1988), Vol II, pp. 131-133, Chicago, Illinois, April 1988.
4. Alan F. Castle. Service Extrusion Consultants "Fixed Dummy Block Extrusion". *Proceedings of the Fourth International Aluminum Extrusion Technology Seminar* (ET 1988), Vol II, pp. 135-138, Chicago, Illinois, April 1988.
5. Robbins, P., "The Contemporary Fixed Dummy Block: Its Design, Operation and Maintenance for maximum Productivity" *Proceedings of the Seventh International Aluminum Extrusion Technology Seminar* (ET 2000), Vol II, pp. 283-287, Chicago, Illinois, May 2000, Aluminum Extruders Council and the Aluminum Association.
6. Robbins, P., Johannes, V, Takagi, S., "The Fixed Dummy Block," *Proceedings of the Eighth International Aluminum Extrusion Technology Seminar* (ET 2004), Vol II, pp. 289-294, Orlando, Florida, May 2004.
7. Robbins, P., Chien, K., "The Critical Interaction of the Dummy Block and Container in Modern Extrusion Presses" *Light Metal Age*, August 2015, pp 8-9.
8. Robbins, P., Chien, K., Jowett, C., Dixon, W., "The Design and Benefits of a Thermally Stable Container". *Proceedings of the Eleventh International Aluminum Extrusion Technology Seminar* (ET 2016).
9. Thyssens - Thyrotherm 2344 EFS product brochure.
10. Lefstad, M., Reiso, O., and Johnsen, V., "Flow of the Billet Surface in Aluminium Extrusion". *Proceedings of the Fifth International Aluminum Extrusion Technology Seminar* (ET 1992), Vol II, pp. 503-517, Chicago, Illinois, May 1992.
11. Hanssen, L., Lefstad, M., Rystad, S., Reiso, O., Johnsen, V., "Billet surface flow in aluminium extrusion using "Half Moon" dies", *Aluminum*, Vol 76, No 3, 2000, pp 138-141, Dixon, W., "Material Flow Related Defects During Extrusion of Aluminium Alloys," *Proceedings of the 2nd Australian-Pacific Extrusion Conference*, 2004.

12. Sano, H., et al., "Study on metal Flow in Extruded Billet," *Proceedings of the Eighth International Aluminum Extrusion Technology Seminar* (ET 2004), Vol I, pp. 47-54, Orlando, Florida, May 2004.
13. Dixon, W., QED Extrusion Developments Inc. "Extrusion Surface Effects Resulting from Billet Surface Inflow". *Proceedings of the Ninth International Aluminum Extrusion Technology Seminar* (ET 2008), Vol 1, pp 245-259, Orlando, Florida, May 2008.
14. Reiso, O., Lefstad, M., Royset, J., and Tundal, U., "Flow of Billet Surface Material during Extrusion of Al Alloys; Effect of Billet Quality and Process Conditions". *Proceedings of the Tenth International Aluminum Extrusion Technology Seminar*, (ET 2012), Vol I, pp. 33 - 47, Miami, Florida, May 2012, Extrusion Technology for Aluminum Profiles Foundation.