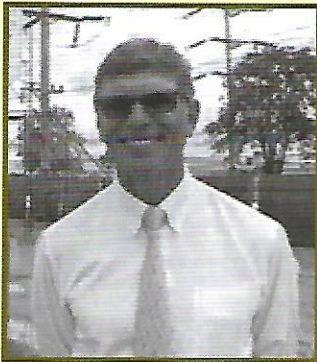
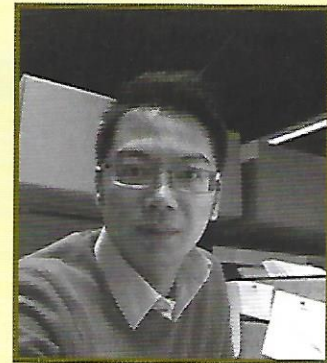


# Plunger Design Meets Caster Requirements

Paul Robinns  
Ken Chien



Paul Robinns  
 GM  
 Castool Tooling Systems  
 Email : probbins@castool.com



Ken Chien  
 Product Director  
 CASTOOL TOOLING SYSTEMS  
 Tel: 905-852-0121 (Canada)  
 Email: ken.chien@castool.com

The demand on high-pressure die casting quality has never been higher. High quality castings require a thermally and dimensionally stable plunger tip and sleeve to control the clearance between plunger OD and shot sleeve ID. The active clearance must be maintained at 0.1mm at all times to prevent aluminum blow-by and excessive wear, therefore generating consistent shot velocity for quality casting. Typically, a die caster can only choose two categories of plunger tips:

1 - a thermally stable plunger made of high strength copper alloy. The wear and strength of the copper alloy tips are lower than H13 (1.2344) steel. The cast quality can be good with high productivity but the initial cost of tip is prohibitive for some die casters.

2 - a steel plunger with low thermal conductivity and its active clearance cannot be controlled. The cast

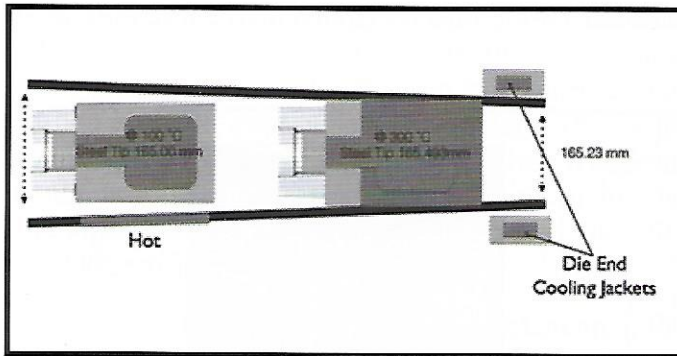
quality is inferior and the productivity is low. The initial cost of tips is low. However, the rejected casts, low productivity and machine down times are huge loss to bear.

Castool has developed a new category of plunger tip. This plunger tip is more thermally stable and tougher than the steel tip, and also has better wear resistance. This tip is designed for long life. It produces better quality casting and productivity than H13(1.2344) or similar steel tip. In addition, the initial cost of the tips are more economical than the H13 steel tips, and of course much more economical than BeCu.

## Conventional steel tip

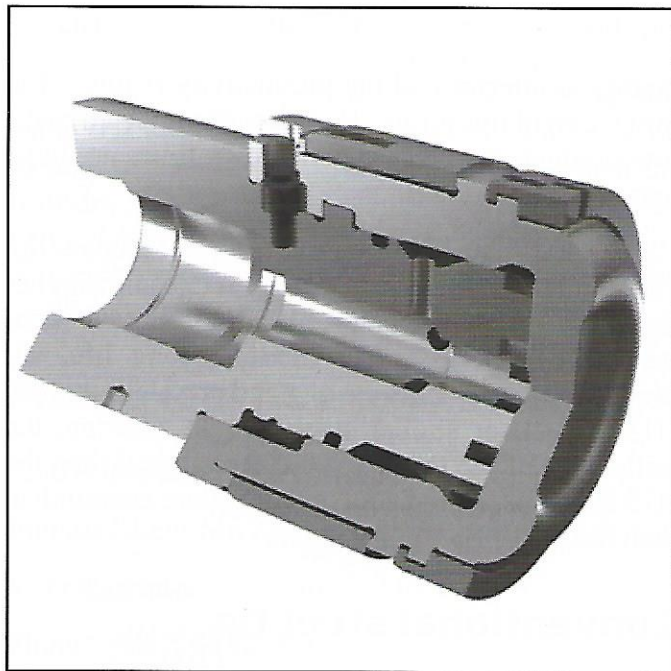
Figure 1 depicts the situation - the steel plunger tip is not thermally and dimensionally stable. The sleeve is hot at the pour end (left end), due to the direct impact

of molten aluminum. The pour end can reach 200°C and cause its ID to expand. The die end is cooled by the water jacket to reduce cycle time and causes its ID to shrink.

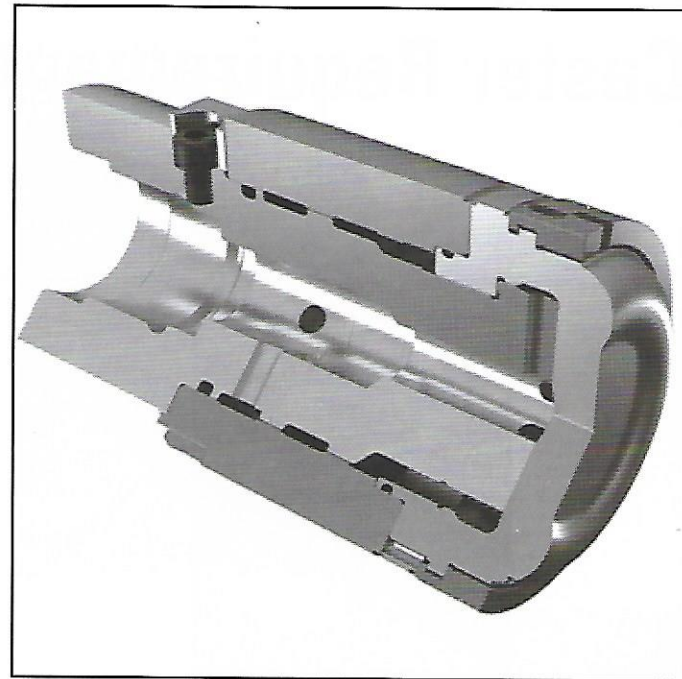


**Figure 1. The plunger tip over expands and sleeve contracts near die end.**

While the solid tip is moving forward, the tip temperature is increased, as is the OD of the tip. The tip may seize or scratch the sleeve when it moves forward. No solid tips will function well under this uncontrolled process. A thermally stable and robust plunger tip is the pre-requisite to having high quality and profitable casting.



**ABP-R with Con Duct body designed for 50 to 120 mm dia**



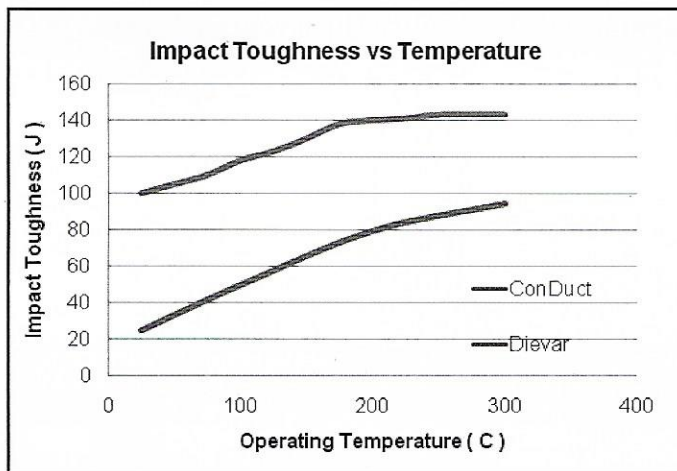
**AMP-R with Con Duct head designed for 120 to 200 mm dia**

## ConDuct: a tougher steel

The Castool plunger tip has a special holder that produces turbulent water and directs the flow to the backside of the plunger face, and returns through several specially designed channels throughout the whole tip body for maximum cooling effect. A conventional plunger tip is only flooded with water, so no high turbulent flow is created. The turbulent flow provides a better heat transfer. The Castool tip is thermally stable and provides excellent cooling to extract heat from the biscuit.

Traditionally, the steel choice for plunger tip material have been H13 (1.2344) or DieVvar steel. These tool steels were developed for strength and hardness during prolonged exposure to elevated temperatures, typically for service temperatures higher than 500°C. However, the plunger tip is constantly being cooled and the temperatures never exceed 300°C and often go as low as 25°C, which hot work steel is not designed to work at that temperature range.

Castool developed a very tough and thermally conductive steel, ConDuct, specifically for plunger tip application. ConDuct steel has very high impact toughness from room temperature up to 300C. At room temperature, the impact toughness of ConDuct is 110J and yetDieVar is only 25J and H13 even less isis only 18J. Figure 2 shows, the toughness of ConDuctis more than twice of the hot work tool steel at all temperatures.



**Figure 2. Impact toughness of ConDuct and Dievar steels**

A plunger tip made of ConDuct steel will be very robust under at all temperatures. The concern, that some microcracks induced by repeated impacts during die casting, is eliminated. The risk of water leaking into the casting to causing porosity and potential explosions is also eliminated.

### ConDuct: A high thermal conductivity steel

The thermal conductivity of ConDuct is 42 W/mk and H13 (1.2344) is only 24 W/mk. ConDuct has 75% better thermal conductivity than H13 (1.2344). By using ConDuct steel and, a thicker shock resistance face can be implemented, yet still provides providing a better heat transfer than a flat H13(1.2344) plunger tip.

A simulation is conducted to compare the plastic strain induced on the plunger tip under 7m/s impact velocity. Figure 3, shows the plastic strain is reduced from 0.0079 ( figure 2a) to 0.004 ( figure 2b). This new face profile eliminates cracks induced by unexpected dry shot during casting.

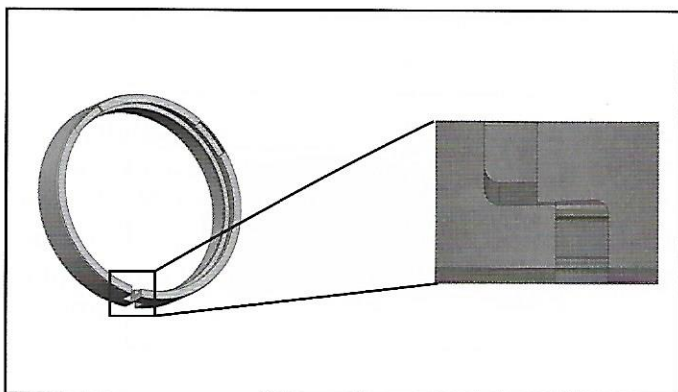


**Figure 2. a) the flat face plunger tip, b) the plunger face with shock resistance face**

The table below shows the thermal conductivity, wear property and working temperature ranges for different plunger component materials. ConDuct steel has better thermal conductivity than H13 (1.2344), and the widest working temperature, from 25C – 550C. H13 (1.234) and Dievar have inadequate toughness below 250C. Copper alloys become annealed above 300C and lose their strength. The higher thermal conductivity of ConDuct makes the plunger tip thermally and dimensionally more stable. The tip temperature difference between ConDuct and H13 tips could differ as much as 45C. The ConDuct plunger tip is more stable and thermal stress is also reduced by 32%.

	Thermal Conductivity (W/mk)	Wear Property (HRc)	Temperature Range (C)
ConDuct	42	35	25 – 550
H13/Dievar	24-30	38	250 – 585
Copper Alloys	150- 230	19 - 29	25 – 300

## Plunger Ring



**Figure 3. anitrided split ring made of H13 to provide excellent wear resistance on tip**

A nitrided split ring made of H13 on ConDucttip creates an exceptionally tough, thermally stable tip with excellent wear property. Figure 3 shows the ring has a wire cut split and two pin slots located 45 degree from the top. The internal radius has been increased by 8 times, reducing the stress concentration by 1/3. The overlap length has also been reduced. The total effective stress from the reduced overlap and increased radius reduces the stress to at least 1/5 of the original milled ring. The locations of pin slots ensure that the split section (usually the weak section) is away from the pout hole erosion and the pour spout. Some sleeves are not thermally regulated properly, and the sleeves IDs are distorted. The two pin slots provide more pivot points for the ring to conform to a distorted sleeve ID and provide a better seal. It is also easier for the operator to access the split for ring removal.

## Conclusion

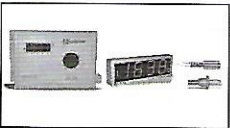


The CastoolConDuct or CD ABP and AMP plunger tips are the most versatile plunger systems available.

The new ConDuct plunger tip has twice the toughness and 75% better thermal conductivity than H-13 or Die Var. It is also tougher than the BeCu and yet is more economical to use than either of these alternatives.

How often is a better solution offered for a significantly better price? Plan your trial today.

\*\*\*

*You Get What We Export*

**Indicators and Display Units**  
 For Molten Metal Temperature Measurements : Cast Iron, SG Iron, Steel  
 Also Offered : V-Tips and V-Multidips

**Digital Temperature Indicators**  
 Controllers, Scanners and Dataloggers  
 Radiation Thermometers

**Indicators and Thermocouples**  
 For Molten Metals - Aluminium, Zinc, Brass, Bronze, Copper, Gunmetal, etc.

- All Types of Thermocouples and RTDs
- Argon Gas Purifiers • Radiation Thermometers
- Pressure and Temperature Calibration Systems
- Heat Treatment Furnace Temperature Mapping Services

**Vi VIJAYESH INSTRUMENTS PVT. LTD.**

Manik Baug, Vadgaon Budruk, Sinhagad Road, Pune - 411 051, India.  
 • Tel. : +91 - 7709011236 / 7709011237 • +91 - 20 - 64700561  
 E-mail : sales@vijayesh.net website : www.vijayesh.net